



Village of Fox Crossing Application for Permit Driveway/Culvert/Curb Cut

Please fill out the following information and return it to the Street Department either in person or by mail at 2000 Municipal Dr. Neenah, WI 54956 or emailing it to streets@foxcrossingwi.gov. If you have any questions please call the Street Department at (920)720-7110.

Office Use Only:

Permit # _____

Receipt # _____

Date _____

APPLICANT INFORMATION:				
Applicant Type (check one):		<input type="checkbox"/> Contractor	<input type="checkbox"/> Property Owner	<input type="checkbox"/> Builder/Developer
Property Owner Name:		Phone Number:		
Job Site Address:				
City:		State:		Zip Code:
Applicants email:				
Contractor/Company Name:			Contractor Phone Number:	
TYPE OF WORK REQUESTED (check one):		<input type="checkbox"/> RESIDENTIAL (40Ft Max)	<input type="checkbox"/> COMMERCIAL (60Ft Max)	
1. LOCATION TYPE:		<input type="checkbox"/> URBAN (Curb & Gutter, Side Walk, Trail) - <i>Please fill out box A</i>		
		<input type="checkbox"/> RURAL (Ditch with Culvert, No Curb & Gutter)- <i>Please fill out box B</i>		
BOX A: URBAN AREA				
1a. <u>Driveway:</u>		Permit Fee:	2a. <u>Curb Cut:</u> Permit Fee:	
<input type="checkbox"/> Replacement-with existing materials		(No Cost)	<input type="checkbox"/> Cutting Backside of Existing Curb \$75	
<input type="checkbox"/> New Driveway with Asphalt		\$125	<input type="checkbox"/> Replacement of Existing Curb & Gutter \$150	
<input type="checkbox"/> New Driveway with Concrete		\$125	* Additional to permit fee you are required to pay the returnable escrow \$2,000	
3a. <u>Curb Cut Information:</u>				
<i>Replacement shall be what the present existing curb wide is (24" or 30"). If it's an interval curb, replacement is a 30" D&G Section.</i>				
Once the curb and gutter work has been completed, please call the Street Department (920-720-7110) for the final inspection to insure proper compliance to the village specifications. Please allow 1-3 business days for the inspection to be complete and once it is approved we will send back the returnable escrow.				
BOX B: RURAL AREA				
1b. <u>Driveway:</u>		Permit Fee:	2b. <u>Culvert:</u> Permit Fee:	
<input type="checkbox"/> Replacement with existing material		(No Cost)	<input type="checkbox"/> New or Replaced \$250	
<input type="checkbox"/> New or Extension with Asphalt or Gravel		\$125	<input type="checkbox"/> Temporary Culvert \$125	
<input type="checkbox"/> New or Extension with Concrete		\$400	<input type="checkbox"/> Culvert Extension \$50	
* Additional to permit fee you are required to pay the returnable escrow \$150				
3b. <u>Culvert Information:</u>				
Culvert Length _____ or		* For new culverts please attach a sketch to permit		
Extension Length _____				
Once you receive the approved permit we will contact our engineer to come take grade shots. Culvert Grade shots are usually done on Fridays. When we receive the shots we will email you that information. Once project is finished please call the Street Department for final inspection to insure proper grade and compliance. Please allow 1-3 business days for the inspection to be complete. Once inspection is approved we will send back the returnable escrow.				
Brand new culverts for new construction builds: You will receive a colored wooden stake which must be placed in the center of the culvert location. Call the Street Department (920-720-7110) when the stake is in place then we will start the grade shot process.				



Village of Fox Crossing Application for Permit Driveway/Culvert/Curb Cut

RETURN ESCROW TO:			
First and Last Name:			
Street Address:			
City/State/Zip:			
ATTACHMENTS:			
Please review the Driveway Policy, Curb Cut Specifications, and Culvert Specifications and Installment Procedures attached to this permit application prior to signing the Agreement to Terms.			
AGREEMENT TO TERMS			
<p>The contractor/property owner described within this permit application understands that once project is completed they must call the street department (920)720-7110 to get a final inspection. If inspection is approved whatever escrow payment will be returned back them around 7-10 business days. If a permit was not taken out prior to the Driveway/Culvert/Curb Cut installation, results in a \$250 late fee plus cost of permit. The contractor/property owner certifies, fully accepts and will comply with all standard specifications and the provisions set forth under Village of Fox Crossing Code Sec. 337-1 through Sec. 337-3.</p>			
_____			_____
Signature of Applicant or Contractor			Date
OFFICE USE ONLY: Total Fees & Permit Approval			
<u>Fees:</u>			
Driveway: _____ <small>(101-5200-440.03-15)</small>	Curb Cut or Culvert: _____ <small>(613-5300-440.03-10)</small>	Escrow: _____ <small>(802-0000-261.03-00)</small>	Permit Total: \$ _____
<u>Permit Approval:</u>			
<input type="checkbox"/> Approved <input type="checkbox"/> Denied			
_____		_____	
Approved By		Date	

		Permit #	

Village of Fox Crossing Driveway Apron Policy

Definitions:

Driveway Apron - The portion of the driveway located from the edge of roadway pavement to the property line, located within the Village right-of-way; not private property.

Unimproved surface - The surface material consists of earth or gravel; not a permanent surface.

Improved surface - The surface material consists of asphalt or concrete material; a permanent surface. Village driveway specifications are as follows:

- Residential Asphalt: 3" asphalt / 12" aggregate base
- Residential Concrete: 6" concrete / 6" aggregate base
- Commercial Asphalt: 4" asphalt / 15" aggregate base
- Commercial Concrete: 8" concrete / 8" aggregate base

Rural roadway - Existing or new construction consisting of open ditch drainage, gravel shoulders, and hot mix asphalt pavement construction.

Urban roadway - Existing or new construction consisting of concrete curb & gutter and storm sewer drainage, and hot mix asphalt/ concrete pavement construction that may include sidewalk and/or a recreation trail.

Street Resurfacing projects:

- Existing rural roadway streets – Existing pavement is removed and replaced with new or recycled hot mix asphalt pavement. A new road crown is established and existing driveway aprons are cut back and adjusted to the new street centerline within the Village's right-of-way.
- Existing urban roadway streets (asphalt only) – Existing pavement is removed and replaced with new or recycled hot mix asphalt pavement. A new road crown is established. Neither the concrete curb and gutter nor the driveway aprons are removed.

Rehabilitation & Reconstruction projects:

- Existing rural roadway streets – Rehabilitation road repairs include replacement of pavement and aggregate base, and is less than 50% of the street. If 50% of the street or more requires replacement, it is then considered a reconstruction project.
- Existing urban roadway streets – Rehabilitation road repairs include replacement of pavement, aggregate base, and/or existing curb & gutter, and is less than 50% of the street. If the repairs are 50% of the street or more, it then is considered a reconstruction project.

Driveway Apron Repair and Replacement Policies (Property Owner Projects):

Property owners assume 100% of the cost of driveway replacement when it is a non-Village project. Damage to existing roadways and/or curb and gutter as a result of the driveway replacement work shall be repaired in-kind.

On a rural roadway, driveway apron material may be replaced in-kind (same material as before). If desired, property owners may choose to upgrade the driveway apron material (unimproved to improved or asphalt to concrete).

On an urban roadway, driveway aprons must be replaced with an improved surface. If desired, property owners may choose to upgrade the driveway material (asphalt to concrete).

It is recommended that property owners review the Driveway Apron Repair and Replacement Policies (Village Projects) on how their driveway may be affected by Village projects.

Driveway Apron Repair and Replacement Policies (Village Projects):

Utility Projects:

- Private utility construction (i.e. telephone, CATV, electric, gas) or public utility construction (i.e. sanitary sewer, water main or storm sewer):
 - For rural roadways, if the proposed work is located on the roadway side of the culvert, the disturbed driveway apron area will be repaired per the Material Replacement Policy.
 - For rural roadways, if the proposed work is located on the property line side of the culvert, the driveway apron will be repaired in-kind.
 - For urban roadways, the disturbed driveway apron area will be repaired per the Material Replacement Policy.
- Resetting or replacing a culvert:
 - If the culvert removal and replacement results in requiring a patch of the driveway apron, the patch area will be in-kind.
 - If the culvert removal and replacement results in driveway apron removal or the property owner wishes to replace the driveway apron, the driveway apron is to be per the Material Replacement Policy.

Material Replacement:

- **Unimproved Driveway Apron:**

On a rural roadway, unimproved driveway aprons will be replaced in-kind at no cost to the property owner.

On an urban roadway, unimproved driveway aprons are not allowed. If a property's driveway apron was unimproved prior to the street improvement, it will be automatically upgraded to asphalt. The cost is 100% the responsibility of the property owner. The work will be completed by the Village's contractor.

- **Asphalt Driveway Apron:**

Asphalt driveway aprons in rural and urban roadways will be replaced in-kind at no cost to the property owner.

- **Concrete Driveway Apron:**

Concrete driveway aprons on rural roadways will be removed and replaced with an asphalt driveway apron at no cost to the property owner.

Concrete driveway aprons on urban roadways will be replaced in-kind at no cost to the property owner.

- **Paver Brick, Stamped/Colored Concrete, and/or other Specialty Materials:**

The installation of paver brick, stamped and/or colored concrete, or other specialty materials is not allowed within the Village right-of-way. During street improvement projects, the Village will remove said apron materials. On rural roadways, these will be replaced with asphalt at no cost to the property owner. On urban roadways, these will be replaced with concrete at no cost to the property owner.

- **Material Replacement Upgrades:**

On a rural roadway – If desired, a property owner may upgrade from an existing unimproved apron to an improved apron or from an existing asphalt apron to a concrete apron. The property owner is required to complete a Driveway Apron Replacement Release Form to allow the Village's contractor to perform the work.

On an urban roadway – If desired, a property owner may upgrade from an existing asphalt apron to a concrete apron. The property owner is required to complete a Driveway Apron Replacement Release Form to allow the Village's contractor to perform the work.

- **Trails and Sidewalks**

If a driveway apron replacement intersects a trail or sidewalk within the Village right-of-way, the more upgraded material will be replaced in the trail or sidewalk. This work will be done at no cost to the property owner, unless the driveway apron replacement is a Material Replacement Upgrade.

Example 1 – if an asphalt trail intersects a concrete driveway, the section of trail at the driveway will be replaced with concrete.

Example 2 – if a concrete sidewalk intersects an asphalt driveway, the section of sidewalk at the driveway will be replaced with concrete.

Driveway Apron Replacement Release Form:

The Village will replace a driveway apron in accordance with the Material Replacement Policy unless the property owner signs a Driveway Apron Replacement Release Form and returns the form to the Village of Fox Crossing Street Department within the required timeframe determined for that roadway improvement project. Upon the property owner signing and returning the form to the Street Department, the Village agrees to replace the driveway apron with the allowed upgraded material. The property owner is then responsible for 100% of the cost of the upgraded driveway apron, which will be billed by the Village to the property owner.

Questions in the interpretation of the Driveway Apron Policy will be clarified by the Director of Public Works.

Curb Cut Specifications

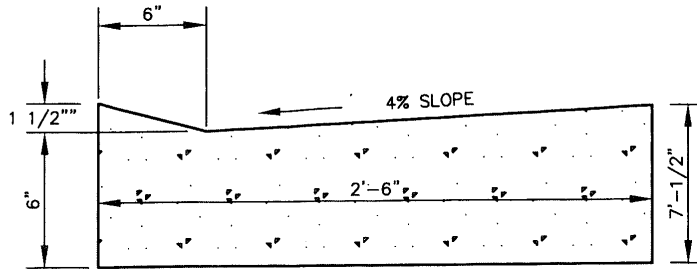

DRIVEWAY OPENING CURB AND GUTTER

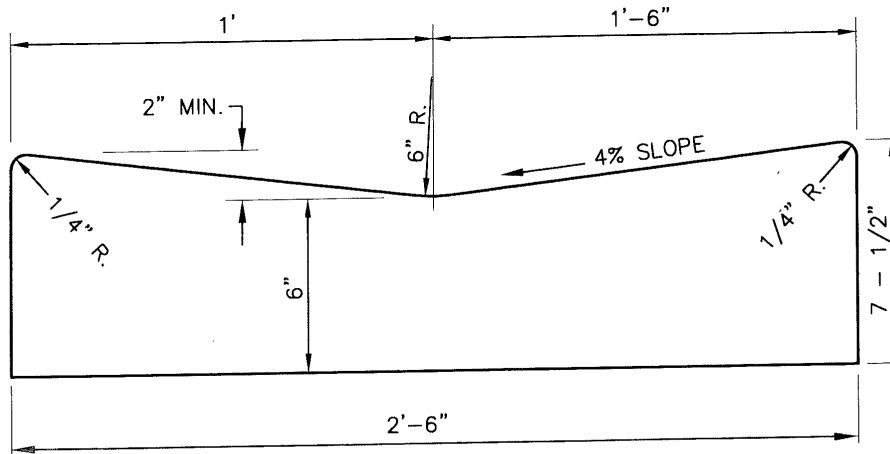

30" MOUNTABLE CURB & GUTTER

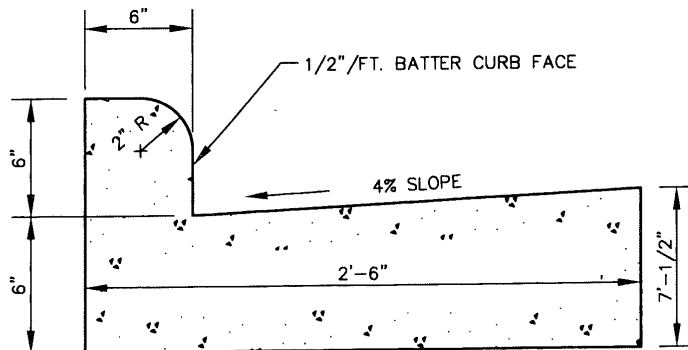

30" BARRIER CURB AND GUTTER

Village of Fox Crossing Culvert Specifications and Installment Procedure

PERMIT

Culverts shall not be installed without a permit. Grade stakes shall be set by the Village of Fox Crossing before installation can begin.

CULVERT & EXTENSION SIZES & LENGTHS

Culvert minimum size is 15" diameter unless authorized by the village. Minimum length of culvert is 24' unless authorized by the village and up to 40', maximum length. Culvert extensions minimum of 2' but no longer than 10' in total length, plus end walls. **Culvert lengths are measured without end walls.** Example: 24' of culvert plus end wall lengths.

MATERIAL

All culverts shall be new material and shall have a fabricated endwall installed at each end. In most cases, culverts shall be of the galvanized corrugated metal type. Oval culverts may be used but must have equal or more flow capacity than the required size of the round type culvert.

PIPE BEDDING

A minimum of 3 inches of crushed stone or gravel is required **UNDER** the culvert.

BACKFILL

Backfill shall be $\frac{3}{4}$ " gravel to the desired driveway grade. Minimum gravel depth over the culvert shall be 8 inches. If the 8 inch minimum cover over the pipe cannot be obtained, an equivalent oval culvert may be required. **NO DIRT BACKFILL IS ALLOWED.**

END WALLS

Only fabricated metal end walls are allowed and must be installed on any new culverts or culvert extensions.

EXTENSIONS

A minimum of a 2' extension is allowed. NO extension shall exceed 10' in length, excluding end walls. The existing culvert and its extension together shall not exceed a total length of 40' excluding end walls.

INSTALLATION PROCEDURE

1. The applicant **MUST** place the wooden stake in the center of the culvert location in the ditch line.
2. Call the Village of Fox Crossing Street Department at 920-720-7110 once the wooden stake is in place.
3. A grade stake will be set five (5) feet from the center of the culvert at each end of the culvert.
4. The “cut” (distance from top of stake to flow line of culvert) will be marked in inches on a lath placed next to the grade stake (see diagram). The street department can also forward a paper copy of the grade sheets once they are prepared by the surveyors.
5. The culvert and end walls can now be installed. Excavate deep enough to allow for the minimum of three (3) inches of gravel underneath the pipe, plus the wall thickness of the pipe. Remember, the “cut” is from the top of the stake to the inside bottom (flow line) of the pipe.
6. Do not remove the grade stakes (laths) until the installation has been inspected by the Village of Fox Crossing.
7. Upon completion of the installation, call the Street Department at 920-720-7110 for a culvert inspection. Culvert escrows will not be released until the culvert is inspected and passes inspection.